

TOOL FAILURE REPORT

Distributor		Warranty Claim No	Date
Hammer Model	Type of Tool	Tool Part Number	Tool Batch No.
Date of Installation	Date of Failure	Working Hours	Other Markings on Tool
Application	Type of Material	Carrier Make / Model	Failure <input type="checkbox"/> Broken <input type="checkbox"/> Worn Out
Original Length in	Length Before Failure L1 in	Length of Upper Part L2 in	Fracture Type <input type="checkbox"/> A <input type="checkbox"/> B <input type="checkbox"/> C <input type="checkbox"/> D
Max Diameter Dmax in	Min Diameter Dmin in	Type of Lubricant	Grease dispenser type <input type="checkbox"/> Manual <input type="checkbox"/> Automatic

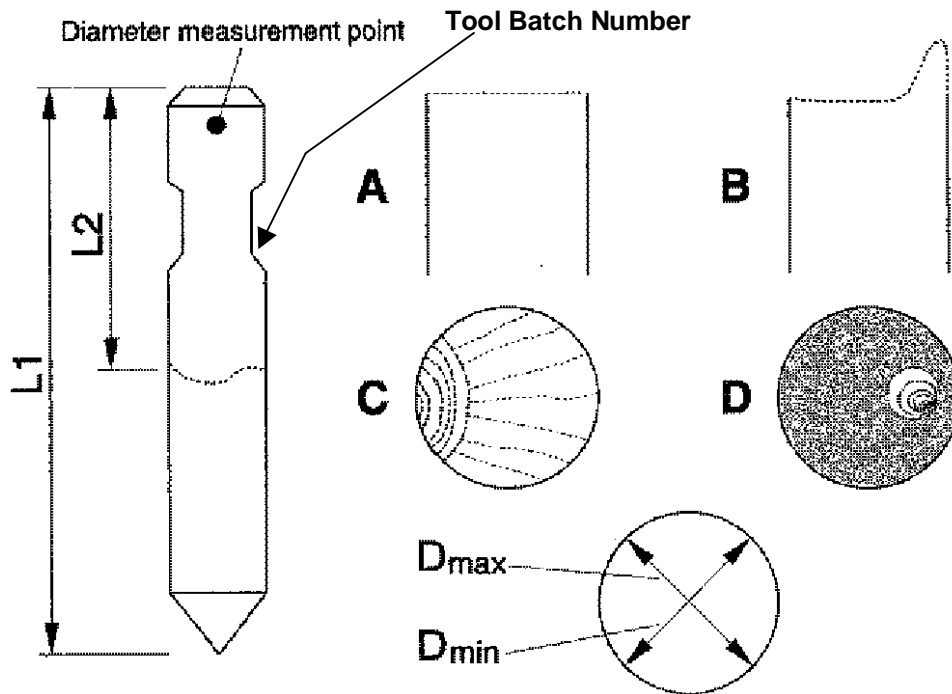

IF CRACKED OR BROKEN, DRAW APPROXIMATE FAILURE LINE IN THE PICTURE OF THE TOOL.

Photos Enclosed

Signature _____

Tool Stored At _____

Print Name _____

Tel: 216-431-2600

Fax: 216-431-2601

Toll-Free: 1-800-321-1046

e-mail: custsvc@alliedcp.com

website: www.alliedcp.com