

AR Series

Hydraulic Impact Breaker

Model
AR 95
AR 95B



ALLIED

Parts Manual



PM101305

Keep this manual in a convenient location so that it is easily accessible for future reference. Contact your Allied Dealer or the Allied Customer Service Department for replacement manuals. Inquiries regarding the content of this manual must include effective date shown on inside cover.

Contact Information



3900 Kelley Ave
 Cleveland, Ohio 44114
 E-mail: sales@alliedcp.com

Tel: 216-431-2600
 Fax: 216-431-2601

Revision History of Document No. PM101305

Continuous improvement of our products is an Allied policy. The material in this publication, including figures, captions, descriptions, remarks and specifications, describe the product at the time of its printing, and may not reflect the product in the future. When changes become necessary, these will be noted in the table below. Specifications are based on published information at the time of publication. Allied Construction Products, LLC, reserves the right to change, edit, delete or modify the content of this document, including descriptions, illustrations and specifications without prior notification. For product or document updates go to www.alliedcp.com.

Table of Revision History

<u>Effective Date</u>	<u>Page</u>	<u>Summary of Change</u>
2015, Feb	6,8,10,12,17,20	Revise AR95B figures and tables to identify introduction of housing box (begin serial number 01114) and introduction of top-down lubrication port (begin serial number 01093).
2013, Feb	14	Table 6.1 correct part number
2011, Jan	7, 14	Item 5 - correct part number. Tune-up kit - correct part numbers.
2009, Sep	Throughout	Update page format, remove specifications
2008, Feb	6	Revise hydraulic adapter configuration
2007, Oct	10	Plunger spring was 101328
2007, Aug		Revise Tune-Up Kit
2007, Jun	7 - 11	Revise Table 4-2, Figure 4-2 & 4-3
2006, Aug	Throughout	Revise figures and tables to identify introduction of Model AR 95B (begin serial number 00045). Suspend production of AR95 (end serial number 00044).
2006, Apr	5	Revise Table 3-2
2006, Jan	19	Revise page format. Add PN 102756 to Decal Kit
2005, Jun	5	Add PN 571053
2002, Oct	3, 4, 6, 15	Mounting designation was SCS, Add CIMA Decal, Revised Parts Figure
2002, Jan	11,12,13	Changed SCS to SSF. Accumulator N2 Gas Filling Kit
2001, Jul	1,16,17	Updated Table - Specs.
2001, Feb	---	Original Issue of Parts Manual 101305

Table of Contents

<u>Section</u>	<u>Page</u>
Document Revisions	i
Table of Contents	ii
1.0 Introduction and Scope	1
1.1 Purpose of This Manual.....	1
1.2 How to Order Replacement Manuals.....	1
1.3 Related Publications.....	1
1.3.1 Safety Operation & Maintenance Manual.....	1
1.3.2 Repair Manual.....	2
1.3.3 AEM Safety Manual - Hydraulic Breakers.....	2
2.0 Equipment Identification	3
2.1 Serial Number Identification.....	3
2.2 Equipment Identification Tag.....	3
2.3 Record of Equipment.....	3
3.0 Safety, Identification, Information Labels	4
4.0 Parts Information	7
4.1 Housing Plates – AR95, AR95B.....	7
4.1.1 Housing Box – AR95B.....	8
4.2 Breaker Assembly.....	9
4.3 Hydraulic Connections.....	13
5.0 Tool Selection Guide	14
5.1 Standard Type Tools.....	14
5.2 Specialty Type Tools.....	14
5.3 Tool Selection.....	15
5.4 Chisel Paste.....	15
6.0 Service Kits and Tools	16
6.1 Tune-up Kit.....	16
6.2 Seal Set.....	17
6.3 Service Tool - Accumulator N2 Gas Charge Kit	19
7.0 Mounting Information	20
8.0 Order Form	21

List of Figures	Page
2-1 Location of Serial Number & Equipment ID Tag	3
2-2 Equipment Identification Tag.....	3
3-1 thru 3-13 Label Description.....	4
3-14 Positions of Safety and Identification Labels	6
4-1 Housing Plates & Components AR95.....	7
4-2 Housing Plates & Components AR95B.....	7
4-3 Housing Box & Components AR95B.....	8
4-4 Breaker Assembly.....	9
4-5 Hydraulic Connections.....	13
5-1 Standard Tools.....	14
5-2 Specialty Tools.....	14
5-3 Tool Diameter & Working Length.....	15
6-1 Tune-Up Kit.....	16
6-2 Seal Set.....	17
6-3 Accumulator N2 Gas Charging Kit.....	19
7-1 Housing Plates – LH / RH Set.....	20
7-2 Housing Box, Mounting Bracket, Bolt Set.....	20
7-3 Connection Plate.....	20

List of Tables	Page
1.1 About This Manual.....	1
3.1 Label Set.....	6
4.1 Housing Plates – AR95.....	7
4.2 Housing Plates – AR95B.....	7
4.3 Box Housing & Components – AR95B.....	8
4.3 Breaker Assembly.....	10
4.4 Hydraulic Connections.....	13
5.1 Tool Selection Guide - Standard & Specialty....	14
5.2 Chisel Paste.....	15
6.1 Tune-up Kit.....	16
6.2 Seal Set.....	18
6.3 Accumulator N2 Gas Charge Tool.....	19
7.1 Mounting Information.....	20

1.0 Introduction and Scope

1.1 Purpose and Scope of This Manual

Table 1.1 About This Manual



Document ID.	PM101305
Type	Spare / Replacement Parts List
Current Status*	See Inside Cover
Product Name:	Mounted Hydraulic Impact Breaker
Series	AR
Applicable Model[s]:	AR95, AR95B
Years of Manufacture:	Begin 2003
*Inquiries regarding this manual must include effective date shown on inside cover	

The material presented in this manual has been prepared in support of the product named in Table 1.1. It's intended solely for use with expressed model(s) and may be unsuitable with models unnamed.

The publication identified in Table 1.1 was created solely for information purposes and should not be considered all-inclusive. If further information is required, contact your local Allied dealer or the Allied Customer Service Department.

Parts Manuals do not include safety precautions or operating procedures. Figures depict views that are intended for parts identification and not for purposes of repair or service of the product. Material presented in this manual, including tables, figures, descriptions and captions, may show equipment that is optional.

How to use this Manual:

The Allied work tool consists of separate components and partial assemblies. Components are identified with the aid of figures, captions, item key, part name and quantity. If needed, 'remarks' and 'specifications' will further clarify the part's description or denote assignment with select unit(s) by serial number.

An order form is provided at the back of this manual. Prior to ordering parts, confirm that the information recorded on the equipment's identification label corresponds with Table 1.1. For the location of this label, refer to Section 2.0 of this manual.

The content of this document has been reviewed for accuracy. Allied Construction Products, LLC has endeavored to deliver the highest degree of accuracy and every effort has made to provide information as complete as possible. However, continuous improvement of our products is an Allied policy. The material in this publication, including figures, captions, descriptions, remarks and specifications, describe the product at the time of its printing, and may not reflect the product in the future. A table of revision history for this document is found on the inside cover.

1.2 How To Order Replacement Publications

This manual is an integral part of this product. Keep it in a convenient location so that it is easily accessible for future reference. If replacement manuals are required, they may be ordered by contacting your Allied dealer service center. Manuals may also be viewed and downloaded at: www.alliedcp.com

1.3 Related Publications

Allied Construction Products, LLC offers the following publications for the product identified in Table 1.1.

1.3.1 Safety, Operation & Maintenance Manual SOM576778

Applicable Models: AR Series 70D,75B,85B,95B

The Safety, Operation and Maintenance Manual has been prepared to assist the operator and maintenance personnel with the information necessary for the safe and proper use of the Allied work tool.

Content in the Safety, Operation & Maintenance Manual includes:

- Safety Information
- Equipment Serial Number and Model Identification
- Technical Data (Weight & General Dimensions)
- Basic Guidelines for Installation and Set-up
- Pre-Operation Inspection
- How to Operate the Allied Work Tool
- Maintenance Schedule
- N2 Gas Charging Instructions
- Tool and Guide Bushing – Lubrication, Inspection, Wear Limits and Replacement
- Troubleshooting
- Removal From Carrier, Transporting, Lifting & Storage

1.0 Introduction and Scope – [cont'd]

1.3.2 Repair Manual A101230

Applicable Models: AR-Series AR48 thru AR95B

The Repair Manual has been prepared to assist the Service Technician with the information necessary for the disassembly & reassembly of the Breaker.

Content includes:

Safety Information

Disassembly & Reassembly

Bolt Torque Specifications

Wear Limits of Parts

Accumulator N2 Gas Charging Instructions

Bushing Replacement

1.3.3 AEM Safety Manual for Hydraulic Breakers

The Association of Equipment Manufacturers offers a safety manual designed for operators and maintenance personnel of hydraulic mounted breakers. The manual is available in Spanish, French and English. It is published in an illustrated format of sensible do's and don'ts, featuring typical daily situations on the job site. Content includes safety tips concerning the workplace and equipment, start up and shut down guidelines and special operating and maintenance precautions.

This publication is available by contacting:

Association of Equipment Manufacturers

Toll free 1-866-AEM-0442

E-mail: aem@aem.org

Website: www.aem.org

Ask for FORM CMHB-1004, Hydraulic Mounted Breakers.

This publication is also available through Allied under part number 953076 (English). To order a copy, contact the Allied Customer Service Department.

2.0 Equipment Identification

2.1 Location of the Serial Number

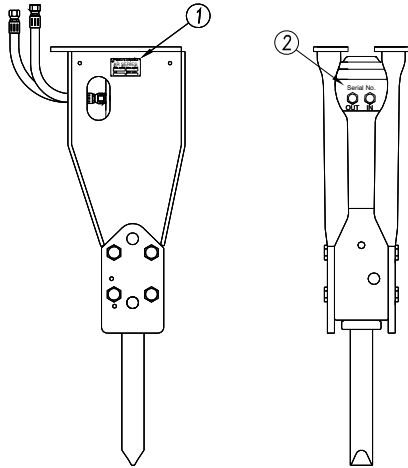

Fig 2-1 Equipment Identification

The Serial Number assigned to this equipment is stamped in the following locations:

- Location 1: Equipment Identification Tag
- Location 2: Valve Housing

2.2 Equipment Identification Tag



Fig 2-2 Equipment Identification Tag

The Equipment Identification Tag is affixed to the housing plates. It provides the following information:

- Manufacturer's name
- Address
- Product name
- Model number
- Serial number
- Year of manufacture
- Weight

Verify that the information contained on the Identification Tag corresponds with the information provided in Section 1 of this manual.

2.3 Owner's Record of the Equipment

Your local Allied dealer requires complete information about the equipment to better assist you with questions regarding parts, warranty, operation, maintenance, or repair.

- Record the equipment's serial number to the space provided below. This information may be obtained from the Equipment Identification Tag. Refer to Fig 2-1 for the location of the tag.
- Indicate the date in which the Allied equipment was placed into service.
- Indicate the date in which the Warranty Registration form was completed and returned to Allied.

Product Name: Hydraulic Breaker

Series: AR

Model / Part No. AR95 / A101302

Model / Part No. AR95B / 572350

Serial Number: _____

In Service Date: _____





Registration Date: _____

3.0 Safety, Identification and Information Labels

3.1 Label Description and Location



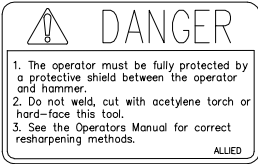

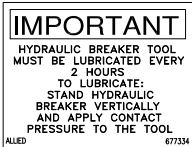
Labels affixed to the Allied equipment communicate important information. Safety labels alert personnel of potential hazards. Other labels provide product identification and instructions important to operation and service. Keep labels clean so that words and

illustrations are readable. Replace damaged or missing labels before operating this equipment. Refer to Table 3.1 for ordering information. Refer to Figure 3-14 for the position of the label on the equipment.

Fig.	Label	Description
3-1		READ THE MANUAL – Safety Alert Symbol with pictogram of open book. It is important to read and understand information and follow instructions contained in the manual.
3-2		STAY CLEAR – Decal alerts personnel and by-standers to maintain a safe distance from the Breaker during operation.
3-3		FLYING DEBRIS – Alerts personnel to the hazard of fragments becoming projectiles. It directs personnel to the Safety, Operation and Maintenance Manual for instructions about the use of a shield between the breaker and machine to protect the operator from injury. NOTE: Place the smaller size decal in a conspicuous location inside the operator’s cab.
3-4		TOOL SHARPENING – Decal warns against welding, cutting, or hard-facing the tool. It directs personnel to the Safety, Operation and Maintenance Manual for approved sharpening methods.
3-5		Pressurized Nitrogen Accumulator – Alerts personnel to the accumulator, warning of nitrogen gas under pressure. Directs personnel to the Safety Operation and Maintenance Manual for service instructions.
3-6		LIFT POINT – Decal identifies approved lift points.
3-7		LUBRICATION – Decal identifies the lubrication point, frequency and importance of proper positioning with contact pressure applied to tool before lubricating.

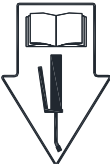
3.0 Safety and Information Labels –[cont’d]

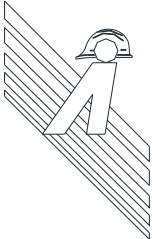
3.1 Label Description and Location -[cont’d]

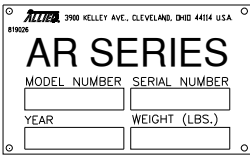
<u>Fig.</u>	<u>Label</u>	<u>Description</u>
3-8		<p>Lubrication Point – Decal identifies lubrication points. Refer to the manual(s) for grease type, re-lubrication schedules and procedures. Risk of equipment damage if instructions are not followed.</p>
3-9		<p>OIL SUPPLY LINE “PRESSURE” I.D. TAG – A red colored cable tie marked “PRESSURE LINE” is attached to the supply hose for ease of identification between hoses.</p>
3-10		<p>Allied “A” with Hard Hat and Background Stripes</p>
3-11		<p>ALLIED LOGO – This decal is the Allied brand identifier and is a registered trademark of Allied Construction Products, LLC.</p>
3-12	<p style="text-align: center;">AR95 AR95B</p>	<p>MODEL – Decal identifies the specific model.</p>
3-13		<p>EQUIPMENT ID TAG - Contains identifying information about the equipment, including: Manufacturer’s name, address, product name, model number, serial number, year of manufacture, and weight.</p>

3.0 Safety & Information Labels- [cont'd]

Figures and descriptions represent standard configurations. Tables and figures are common to all serial numbers except where noted.

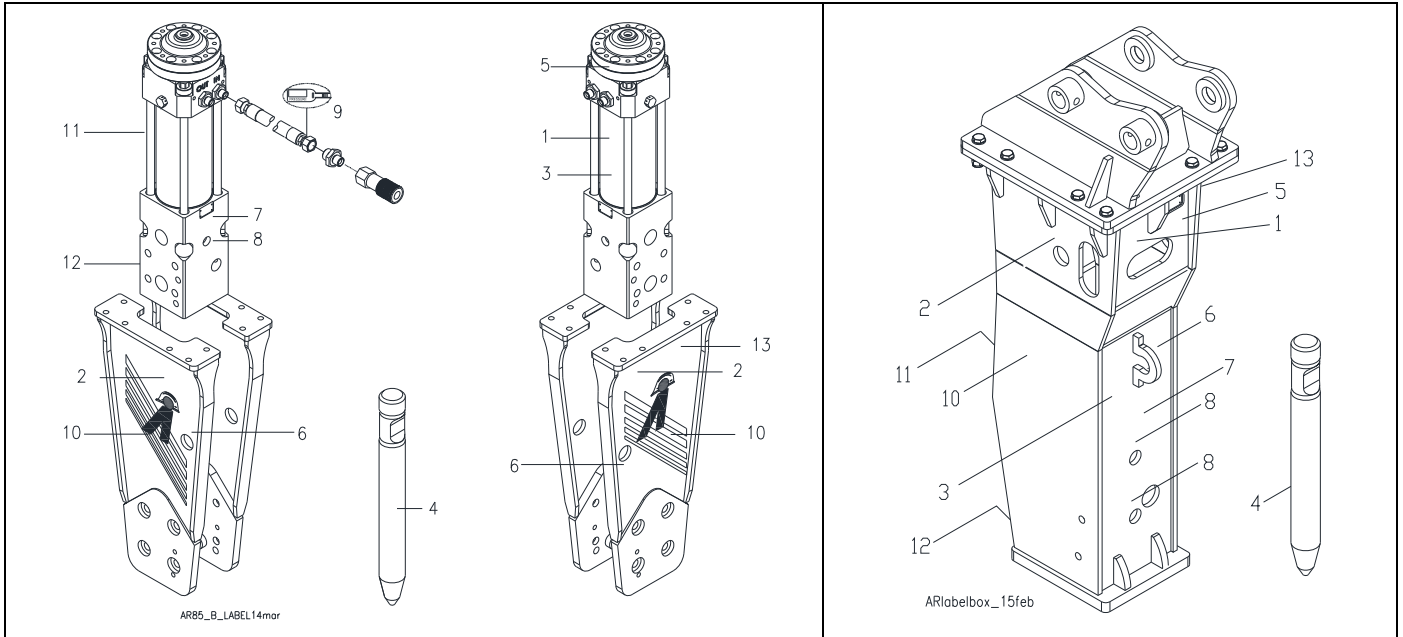

Fig. 3-14 Label Positions

Table 3.1 Label Set

<u>Item</u>	<u>Description</u>	<u>Part No.</u>	<u>Model</u>	<u>Qty</u>	<u>Remarks / Specifications</u>
---	Label Set Complete-AR95	101306		1-Set	Set includes 1-12
---	Label Set Complete-AR95B	572355	B	1-Set	Set includes 1-12
1	Decal – Read the Manual / Instructions	676984		1	
2	Decal – Stay Clear	657841		2	
3	Decal – Danger (Small)	657839		2	Place one of these in conspicuous location inside cab
4	Decal – Tool Sharpening	657838		1	
5	Decal – Pressurized Accumulator	102756		1	
6	Decal – Lift Point	676982		2	
7	Decal – Lube w/ Tool In	677334		1	
8	Decal – Lubrication Point	A101725		1	
9	Pressure ID Tag	818676		1	Attach to supply hose [IN]
10	Decal – Allied “A” w/ Stripes	576280		2	
11	Decal – Allied Logo	576287		1	
12.1	Decal – Model AR95	101341			
12.2	Decal – Model AR95B	572356	B	1	
13	Equipment ID Tag	819026		1	Item 13 not included in Set

4.0 Parts Information – Housing Plates

Figures and descriptions in the parts manual represent standard configurations. Tables and figures are common to all serial numbers except where noted.

4.1 Housing Plates

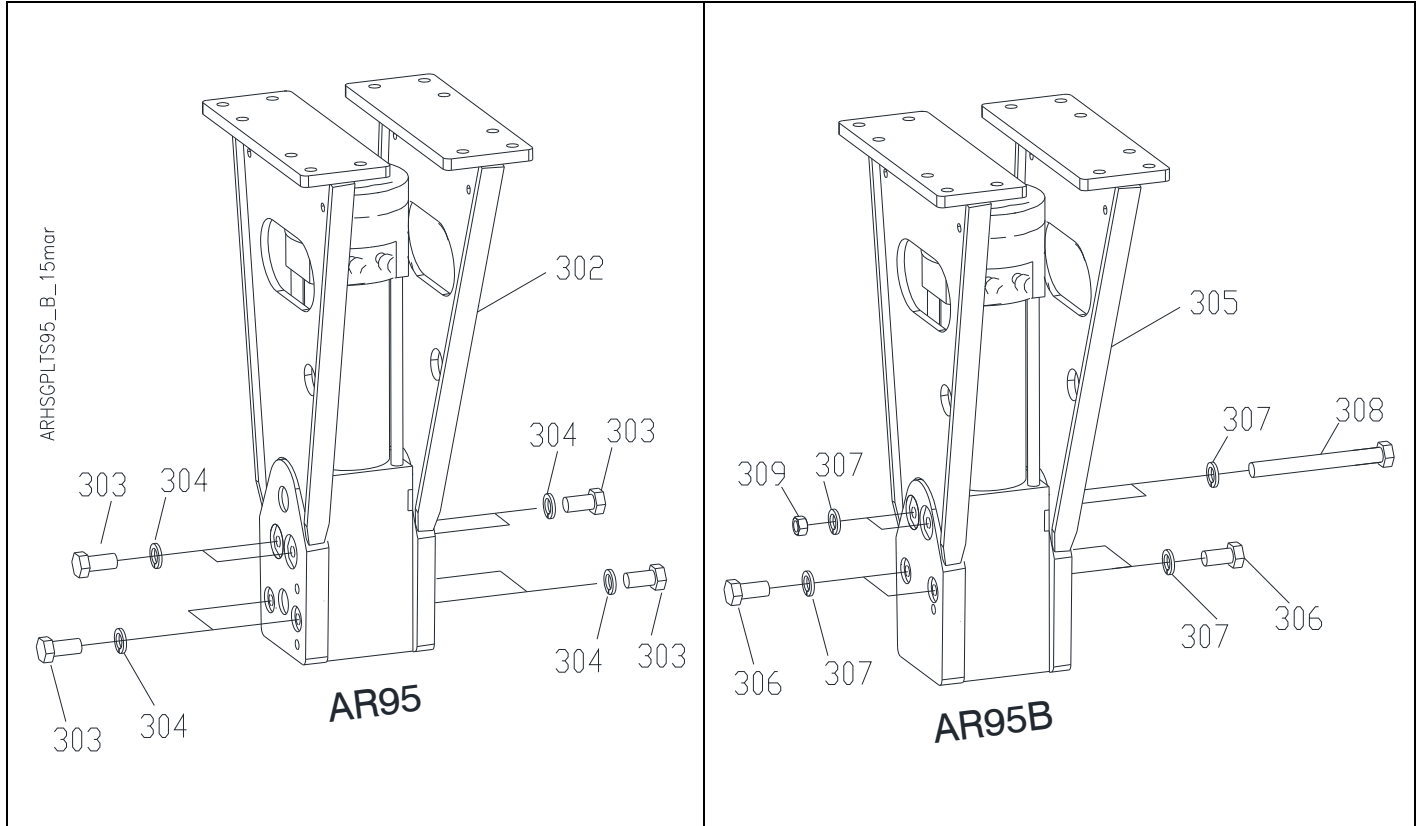

Fig. 4-1 Housing Plates – AR95

Fig. 4-2 Housing Plates – AR95B

Table 4.1 Housing Plates – AR95 (Fig. 4-1)

<u>Item</u>	<u>Description</u>	<u>Part No.</u>	<u>Qty</u>	<u>Remarks / Specifications</u>
302	Housing Plates Set LH / RH	101063	1-Set	Std Config. SR / SCS
303	Hex Head Bolt	658559	8	M30 x 55
304	Lock Washer	658560	8	M30

Table 4.2 Housing Plates – AR95B (Fig. 4-2)

<u>Item</u>	<u>Description</u>	<u>Part No.</u>	<u>Model</u>	<u>Qty</u>	<u>Remarks / Specifications</u>
305	Housing Plates Set LH / RH	572347	B	1-Set	Std Config. SR / SCS
306	Hex Head Bolt	658559	B	4	M30 x 50
307	Lock Washer	658560	B	8	M30
308	Hex Head Bolt	572537	B	2	M30 x 280
309	Hex Nut	572538	B	2	

4.1 Housing Plates

Figures and descriptions represent standard configurations. Tables and figures are common to all serial numbers except where noted.

4.1.1 Housing Box – AR95B (Serial Number Begin 01114)

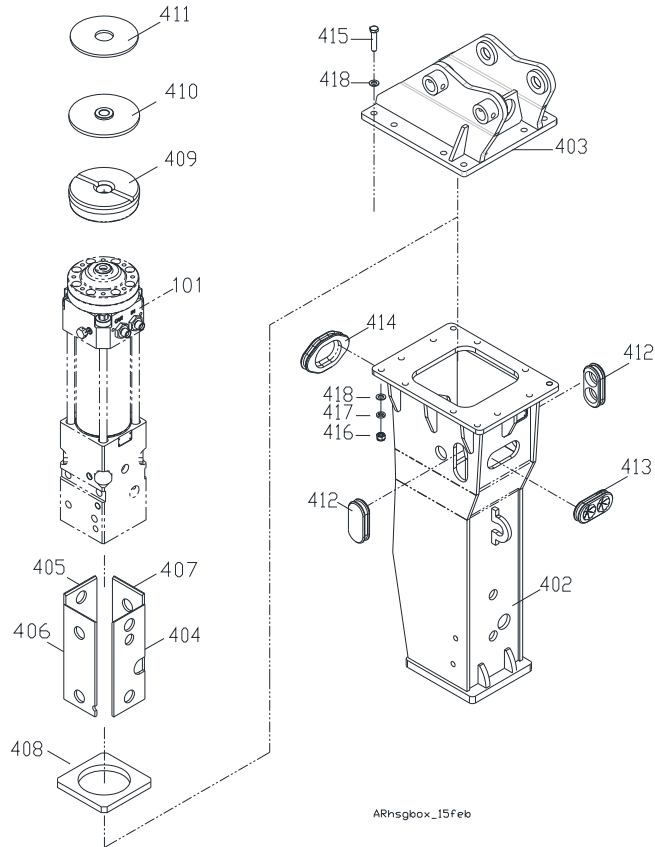

Fig 4-3 AR95B Housing Box and Components

Table 4.3 Housing Box – AR95B (Serial Number Begin 01114)

Item	Description	Part No.	Model	Qty	Remarks / Specifications
101	Breaker Assembly	---	B	1	Std Configuration
402	Housing Box		B	1-Set	Std Config. SR / SCS
403	Mounting Bracket	Varies	B	---	Not included. Order separately.
404	Wear Plate	B1000030	B	1	
405	Wear Plate	B1000040	B	1	
406	Wear Plate	B1000050	B	1	
407	Wear Plate	B1000060	B	1	
408	Buffer – Bottom	B1000070	B	1	
409	Buffer - Top	B1000080		1	
410	Top Plate Ass'y	B1000090	B	1	
411	Top Wear Plate	B1000100	B	1	
412	Plug	B1006800	B	2	
413	Plug	B0806820	B	1	
414	Plug	B1000130	B	1	
415	Bolt Set	---	B	1	415,415,417,418 Refer to Table 7.1

4.2 Breaker Assembly

Figures and descriptions represent standard configurations. Tables and figures are common to all serial numbers except where noted.

4.2 Breaker Assembly

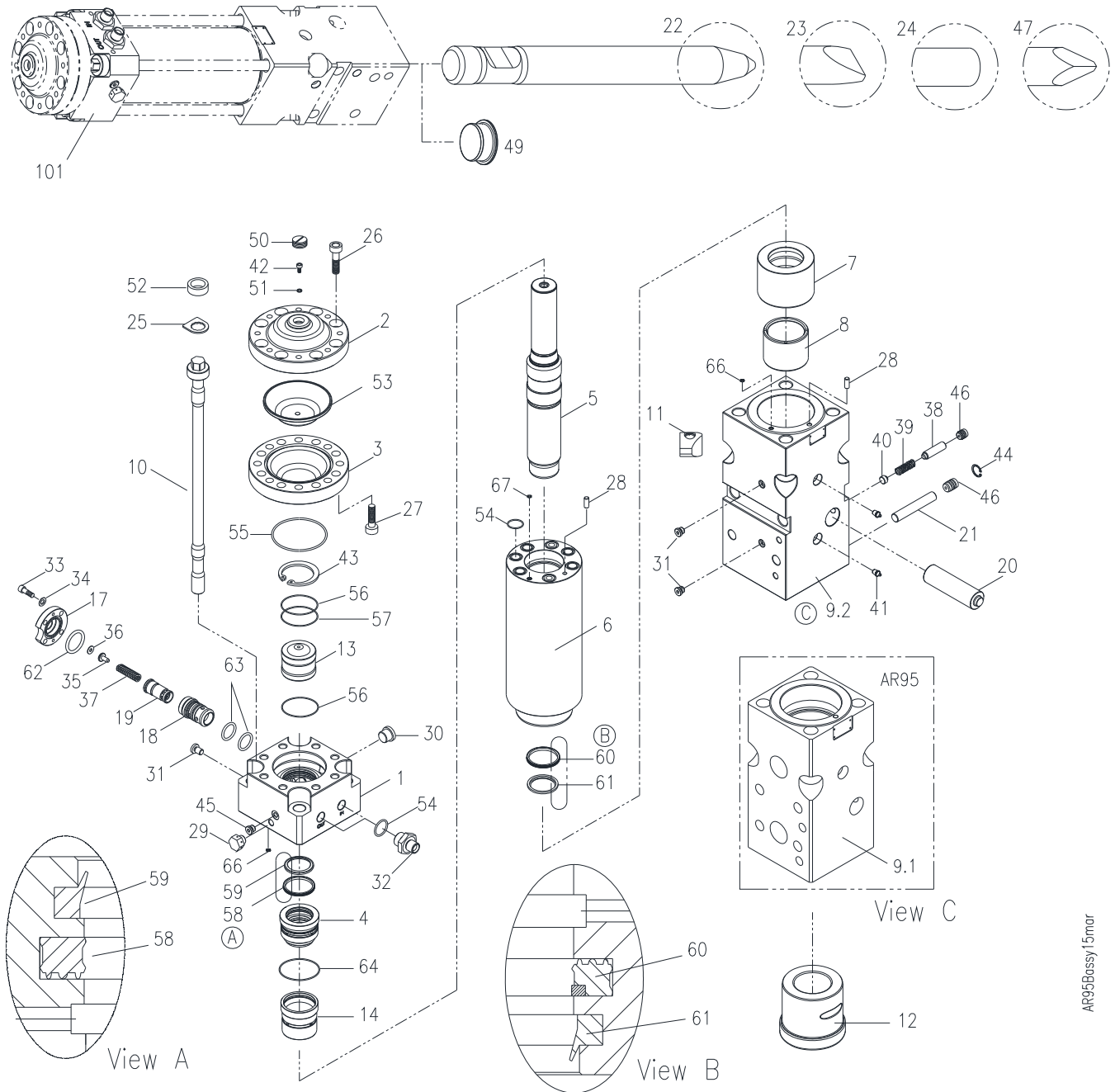

Fig. 4-4 Breaker Assembly – AR95, AR95B

AR95Bossy15mar

4.2 Breaker Assembly

Figures and descriptions represent standard configurations. Tables and figures are common to all serial numbers except where noted.

Table 4.3 Breaker Assembly – AR95, AR95B

<u>Item</u>	<u>Description</u>	<u>Part No.</u>	<u>Model</u>	<u>Qty</u>	<u>Remarks / Specifications</u>
1.1	Valve Housing	101307	B ²⁾	1	²⁾ SN-01093&UP
1.2		B1006710			
2	Accumulator Cover	101308		1	Upper
3	Accumulator Cover	101309		1	Lower
4	Seal Housing	A101310		1	
5	Piston	101311		1	
6.1	Cylinder	101312	B ²⁾	1	²⁾ SN-01093&UP
6.2		B1006720			
7	Thrust Ring	101321		1	
8	Tool Bushing, Upper	101320		1	
9.1	Front Head	101313			Early AR95 ^{a)} SN-00044&DOWN
9.2		572348	B ¹⁾	1	¹⁾ SN-00045 thru 01055
9.3		B1006730	B ²⁾		²⁾ SN-01093&UP
10	Side Rod	101314		4	
11	Side Rod Nut	101315		4	
12	Tool Bushing, Lower	101317		1	
13	Bushing	101325		1	
14	Distributor	101319		1	
17	Regulator Cover	676230		1	
18	Regulator Guide	676226		1	
19	Regulator Spool	676227		1	
20	Tool Retainer Pin	101316		1	
21	Bushing Pin	101324		1	
22	Tool Selection	Varies		1	Items 22,23,24,47 Refer to Table 5.1
25	Lock plate, Side Rod	101318		4	
26	Socket Head Bolt	101326		8	M18
27	Socket Head Bolt	676163		8	M16
28	Guide Pin	101322		2	
29	Vent Plug	676215		1	
30	Threaded Plug	676216		1	
31	Threaded Plug	676159		3	
32	Adapter	966080		2	
33	Socket Head Bolt	940587		4	
34	Disc Lock Washer	571053		4	

4.2 Breaker Assembly

Figures and descriptions represent standard configurations. Tables and figures are common to all serial numbers except where noted.

Table 4.3 Breaker Assembly AR95, AR95B –[cont'd]

<u>Item</u>	<u>Description</u>	<u>Part No.</u>	<u>Model</u>	<u>Qty</u>	<u>Remarks / Specifications</u>
35	Regulator Spring Guide	676228		1	
36	Regulator Shim Plate	676229		1	
37	Regulator Spring	676225		1	
38	Plunger Pin	100026		1	
39	Plunger Spring	100027		1	
40	Plunger Pin Spring Guide	676195		1	
41	Lubrication Fitting	816675		1	
42	Gas Bolt	676161		1	
43	Snap Ring	101329		1	
44	Snap Ring	103034		1	
45	Threaded Plug	102241	B ²⁾	1	²⁾ SN-010193&UP
46	Rubber Plug	676243		2	
49	Plug	---		1	
50	Protective Cap	676157		1	
51	Usit Ring	676201		1	
52	Rubber Ring	101327		4	
53	Membrane	101331		1	
54	O-Ring	676204		9	
55	O-Ring	101330		1	
56	O-Ring	101338		2	
57	Back-Up Ring	101339		1	
58	Seal, Upper	101332		1	
59	Wiper, Upper	101333		1	
60	Seal, Lower	101335		1	
61	Wiper, Lower	A101336		1	
62	O-Ring	676251		1	
63	O-Ring	676206		2	
64	O-Ring	101334		1	
66	O-Ring	A2007220	B ²⁾	2	²⁾ SN-01093&UP
67					

4.3 Hydraulic Connections

Figures and descriptions represent standard configurations. Tables and figures are common to all serial numbers except where noted.

4.3 Hydraulic Connections

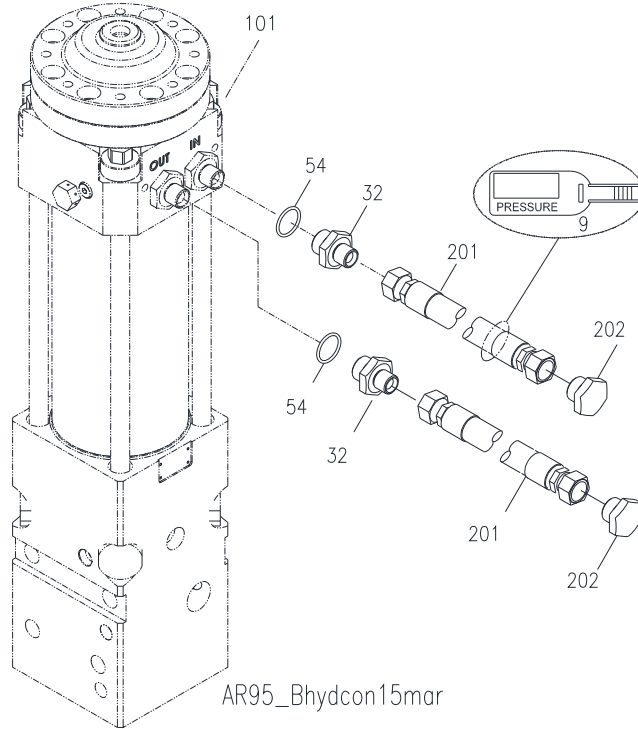

Fig 4-5 Hydraulic Connections

Table 4.4 Hydraulic Connections – AR95, AR95B

<u>Item</u>	<u>Description</u>	<u>Part No.</u>	<u>Qty</u>	<u>Remarks / Specifications</u>
9	Pressure ID Tag	818676	1	Located On Supply Hose [IN]
32	Adapter	966080	2	
54	O-ring	676204	2	
201	Hose Assembly	719098	2	
202	Plug	814454	2	

5.0 Tool Selection Guide – Standard & Specialty

5.1 Standard Tools

The three most commonly used tool points for concrete demolition rock cutting and boulder reduction are the Chisel, Conical and Blunt.

A. **Chisel (Wedge – Cross Cut or In-Line)** – Suitable applications include soft rock and general demolition of concrete. The tool penetrates into the material, forcing it to separate. Useful when cutting action is required, e.g. benching and trenching.

B. **Conical Point** - The conical point penetrates the material and its shape makes it less prone to twisting which can lead to burring of the tool's retainer pin.

C. **Blunt Tool** – Designed for impact breaking. The blunt tool is effective in secondary breaking of oversize rock or boulder reduction.

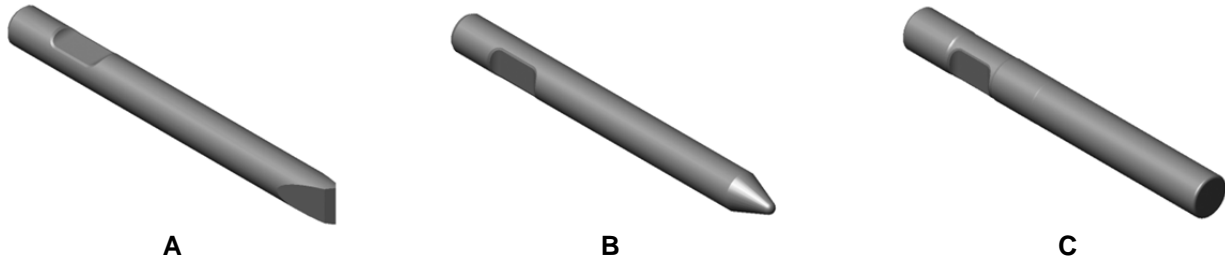

Fig. 5-1 Standard Tool Types A thru C.

5.2 Specialty Tools

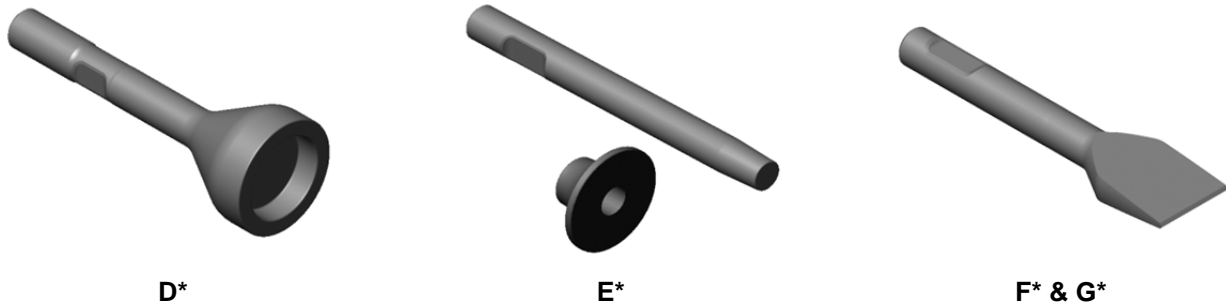

Fig 5-2 Specialty Tool Types D thru G.

Specialty tools have a specific purpose or function designed into each tool. These tools can extend the versatility of a breaker, thus increasing productivity and eliminating the need for additional equipment.

General illustrations are shown. Actual tool design may vary.

*Not available for all models.

For availability of tool types not listed, contact Allied.

D. **Post Driver** – For driving posts, pipes, etc.

E. **Tamper** – Designed to compact loose material.

F. **Frost Cutter** – For cutting into frozen ground.

G. **Asphalt Cutter** – Designed to cut seams in asphalt for removal. Useful when removing asphalt to dig a trench. Available in Cross-Cut and In-Line configurations.

5.0 Tool Selection Guide – [cont'd]

Figures and descriptions represent standard configurations. Tables and figures are common to all serial numbers except where noted.

5.3 Tool Selection

Table 5.1 Standard Tools – AR95, AR95B

Item	Description	Part No.	TD x WL in. [mm]	Weight-lbs. [kg]
34-B	Conical Point	101071	3.74 [95] x 23 [584]	99 [45]
35-A¹	Chisel Cross Cut	101072	3.74 [95] x 23 [584]	102 [46]
---	Chisel In-Line	101073	3.74 [95] x 23 [584]	102 [46]
36-C	Blunt End	A101074	3.74 [95] x 23 [584]	105 [48]
---	Moil (Not Pictured)	--- ²	---	---

- 1) **Standard tool supplied with Breaker**
- 2) For availability of tool types not listed, contact Allied
- 3) TD- Tool Diameter
- 4) WL-Working Length

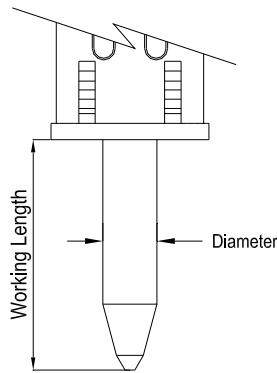

Fig. 5-3 TD & WL

Allied Chisel Paste performs exceptionally well in this application due to its 'unique blend' of liquid and dry film lubricants. Dry film lubricants, which include solids of molybdenum, graphite and copper, combine to form a highly effective layer that resists being squeezed out during periods of heavy loading (extreme pressure).

Grease labeled 'General / Multi-Purpose' will typically contain only modest amounts of solid lubricants or none at all. When the tool is loaded against the bushing, the liquid lubricant is squeezed out, leaving metal surfaces unprotected.

5.4 Lubricant For Bushing and Tool

5.4.1 Allied Chisel Paste

Wear costs money, sometimes lots of money. Without lubrication to prevent metal-to-metal contact, bushings and tools will quickly wear from friction related damage.

A key element in managing wear of the bushing and tool is through the regular use of a high-quality lubricant. Formulated as a 'specialty' lubricant, Allied Chisel Paste is ideally suited for use in applications requiring long-lasting protection against damage from heavy loaded, sliding motion and high heat.

5.4.2 Ordering Information

Table 5.2 Chisel Paste

Container	Packaging	Part No.
14.5 oz. Cartridge*	Qty x 10	574430
14.5 oz. Cartridge*	Qty x 30	574431
35 lbs. Bucket	Qty x 1	676698
120 lbs. Drum	Qty x 1	679968

*Cartridge fits standard hand-type grease gun

6.0 Service Kits and Tools

6.1 Tune-up Kits

All breakers require regular maintenance and periodic replacement of wear parts. Follow the recommended service schedule to maintain reliable operation.

Tune-up kits can help restore performance by replacing common wear parts. Tune-up kits offer the convenience of combining parts that usually need to be replaced at the same time into a single package.

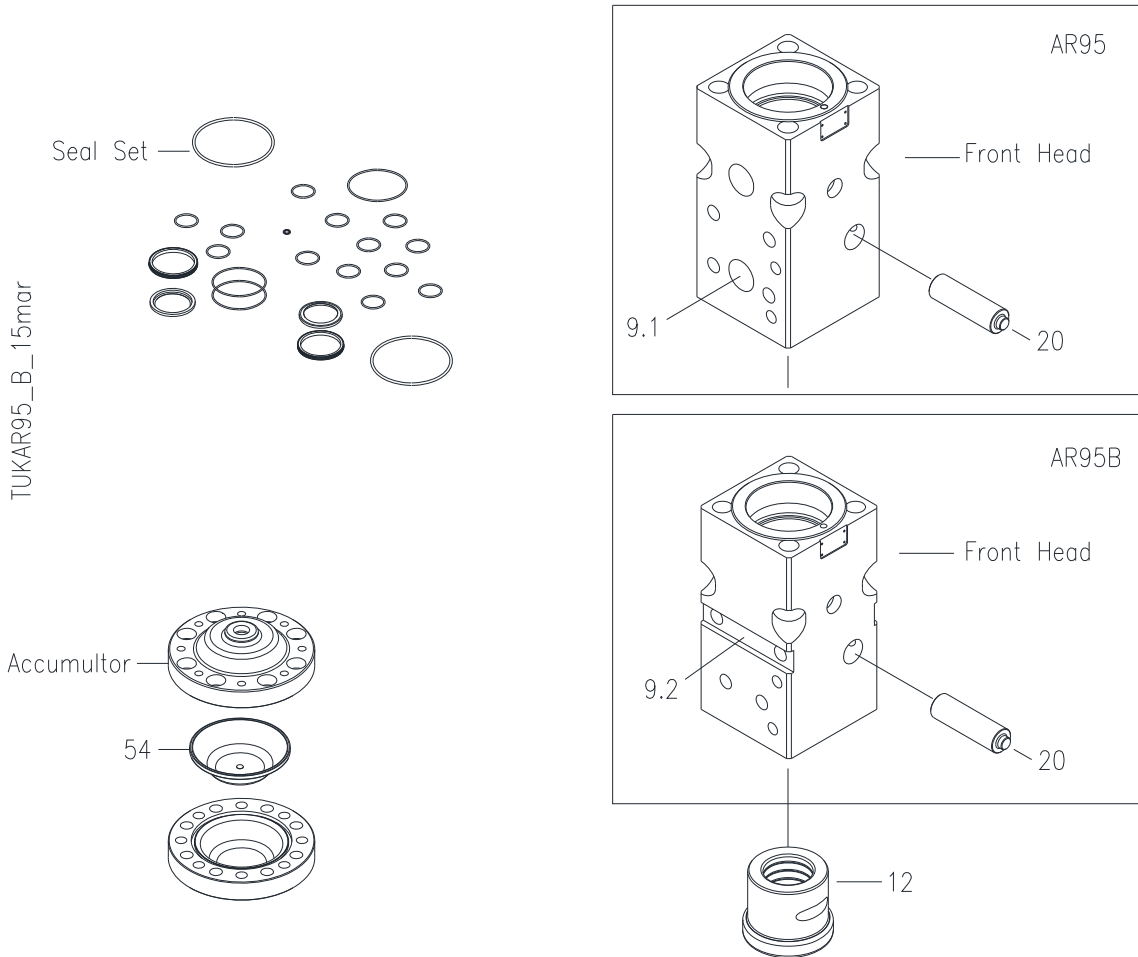

Fig. 6-1: Tune-Up Kit – Model AR95 & AR95B

Table 6.1 Tune-Up Kit – AR95, AR95B

Item	Description	Part No.	Qty	Remarks / Specifications
---	Tune-up Kit	101354	1-Kit	Kit includes items listed
---	Seal Set Complete	101348	1	Refer to Table 6.2
12	Lower Tool Bushing	101317	1	
20	Tool Retainer	101316	1	
54	Accumulator Membrane	101331	1	

Figures and descriptions represent standard configurations. Tables and figures are common to all serial numbers except where noted.

6.0 Service Kits and Tools – [cont'd]

Figures and descriptions represent standard configurations. Tables and figures are common to all serial numbers except where noted.

6.2 Seal Set - 101348

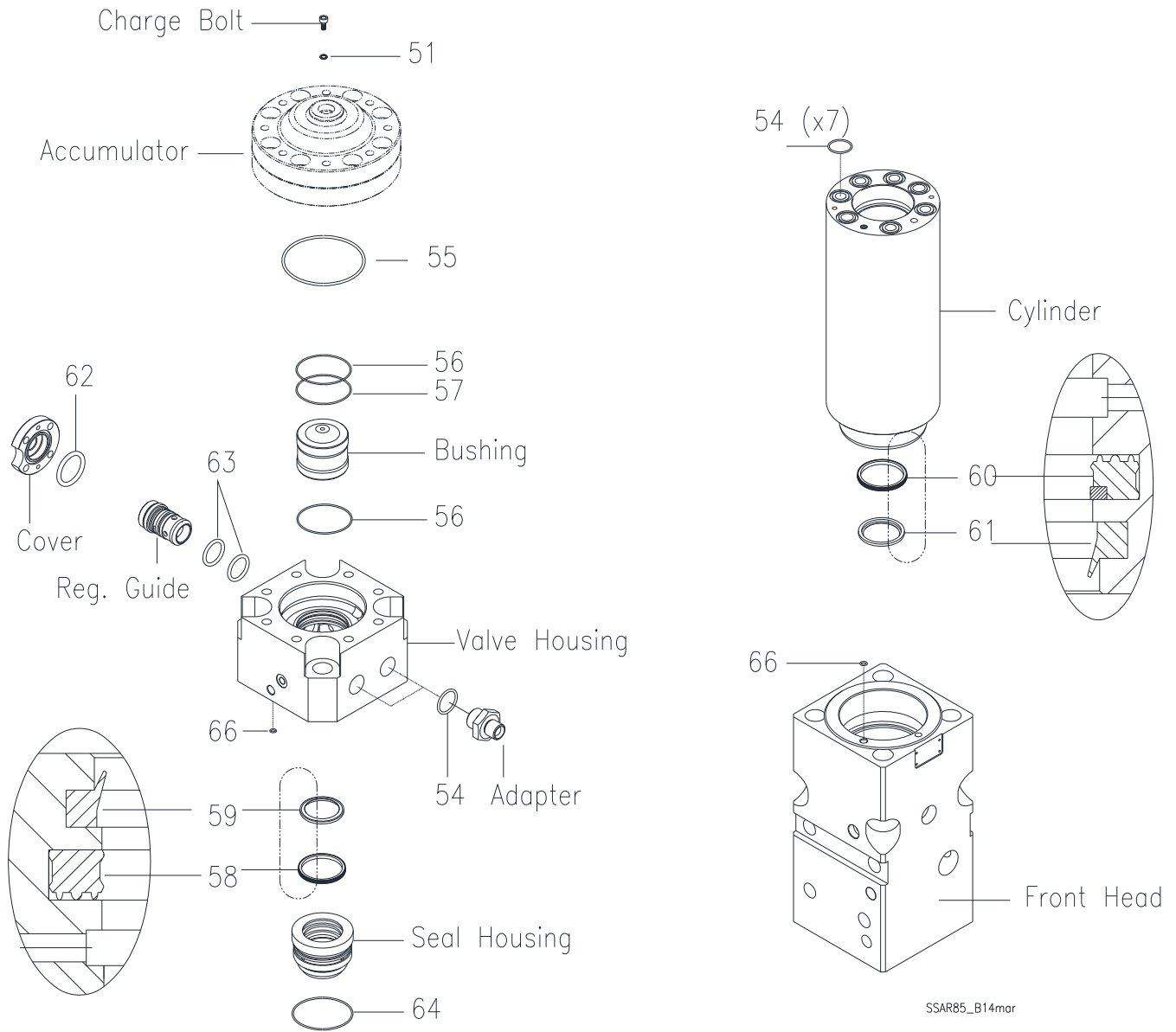

Fig. 6-2: Seal Positions – AR95 & AR95B

6.0 Service Kits and Tools – [cont'd]

Figures and descriptions represent standard configurations. Tables and figures are common to all serial numbers except where noted.

Table 6.2 Seal Set Complete – AR95 and AR95B

<u>Item</u>	<u>Description</u>	<u>Part No.</u>	<u>Model</u>	<u>Qty</u>	<u>Remarks / Specifications</u>
---	Seal Set	101348		1 Set	Set includes items listed
51	Usit Ring	676201		1	
54	O-Ring	676204		9	
55	O-Ring	101330		1	
56	O-Ring	101338		2	
57	Back-Up Ring	101339		1	
58	Seal, Upper	101332		1	
59	Wiper, Upper	101333		1	
60	Seal, Lower	101335		1	
61	Wiper, Lower	A101336		1	
62	O-Ring	676251		1	
63	O-Ring	676206		2	
64	O-Ring	101334		1	
66	O-Ring	A2007220	B ²⁾	2	²⁾ SN-01093&UP
---	Thread Lube 2 oz.	676927		1	Follow application instructions

 	Follow all instructions given in Repair Manual, part number 101230.
---	---

IMPORTANT
Contamination interferes with reliable operation and will shorten component life. Prevent dirt and debris from entering the hydraulic system. Always work in a clean area. Keep seals properly stored in their original, sealed package until ready for use.

IMPORTANT
Apply thread lube included in seal set to threads of side rods at assembly. <i>DO NOT apply Thread Lube to seals!</i>

6.0 Service Kits and Tools – [cont'd]

6.2 Accumulator N2 Gas Charge Equipment

The accumulator is a self-contained pressure vessel, designed to help the breaker operate efficiently and reliably. An elastic membrane (A) divides the inner chamber. The lower chamber receives, stores and discharges pressurized oil. The upper chamber is pressurized with nitrogen gas (N2).

Pressurizing (pre-charging with dry nitrogen gas) the accumulator is accomplished with the charging tool (Fig. 6-3). The table below lists the items included with the charging kit. The kit will service most accumulators found on the AR-series breakers. NOTE: The nitrogen bottle (E) gas is NOT included.

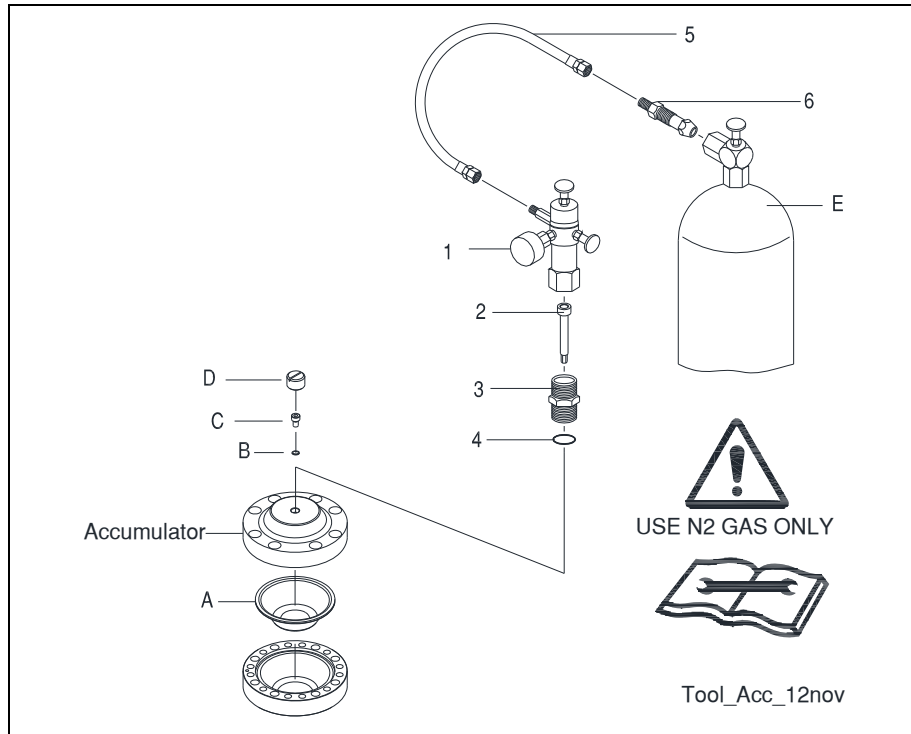



Fig. 6-3 Accumulator N2 Gas Charge Tool

Table 6.3 Accumulator N2 Gas Charge Kit

Item	Description	Part No.	Qty	Remarks / Specifications
---	N2 Gas Charge Kit	570071	1-Kit	Kit includes items 1,2,3,4,5,6
1	Charge Valve with Gauge	100527	1	Items 2-6 & storage case (not shown)
2	Socket Bolt	40601	1	
3	Adaptor	R101635	1	
4	O-ring	901135	1	
5	Hose	N/A	1	8 Ft. [2.5 M] Not Available Separately
6	Adapter for N2 Gas Bottle	N/A	1	Not Available Separately
E	Nitrogen Gas Bottle	N/A	---	Not Available from Allied (Source Locally)
A,B,C, D,E	Membrane, U-sit ring, Bolt, Cap, N2 Gas Bottle	---	---	A,B,C,D,E Shown only for reference and are not included in charge kit.

  For safe and proper use of this tool, read, understand and follow all instructions given in Safety, Operation and Maintenance Manual part number 576778.

7.0 Mounting Information

7.1 Housing Types and Mounting Brackets

The Breaker assembly is equipped with either housing plates (Fig. 7-1) or housing box (Fig. 7-2, item 402). Installation of a mounting bracket (sold separately) is required before the Breaker can be attached to a carrier. Allied offers an array of bolt-on mounting brackets to fit virtually any carrier, including those equipped with pin-grab or hook-type quick mounting couplers.

7.2 Connection Plate

The mounting bracket (Fig. 7-2, item 403) is bolted to the connection plate (Fig. 7-3) located at the upper end

of the housing plates/box. The dimensions of the connection plate, including thickness, spacing, quantity and diameter of the bolt holes, can be found in the Safety, Operation & Maintenance Manual.

In Table 7.1, the mounting “Family” designates a sizing system used by Allied to identify a given connection plate. Other Allied work tools, including the Ho-Pac[®], utilize these same mounting Families.

Figures and descriptions represent standard configurations. Tables and figures are common to all serial numbers except where noted.

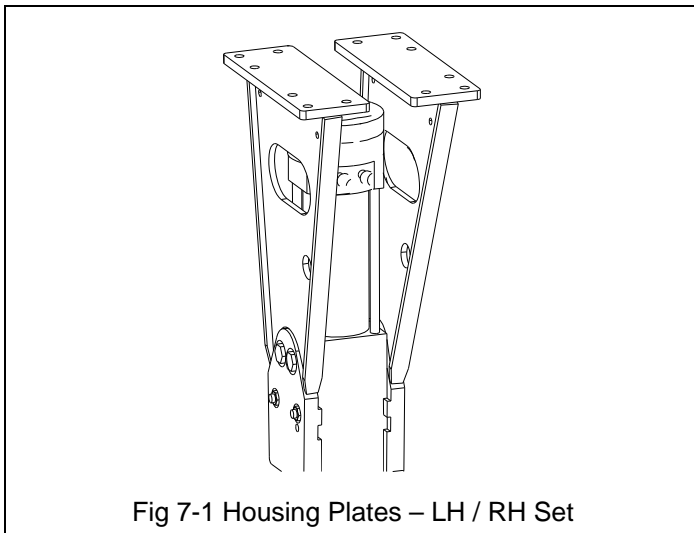

Fig 7-1 Housing Plates – LH / RH Set

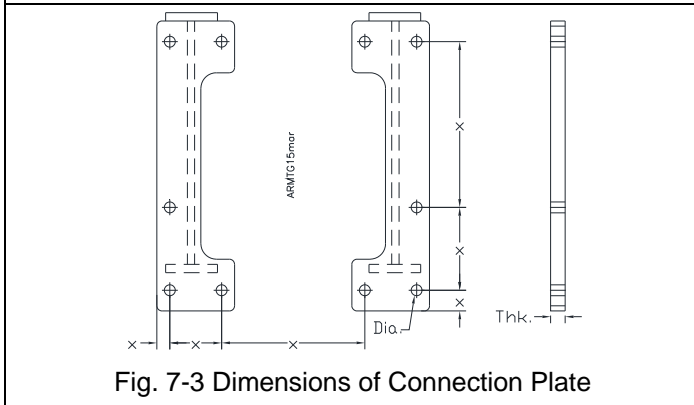

Fig. 7-3 Dimensions of Connection Plate

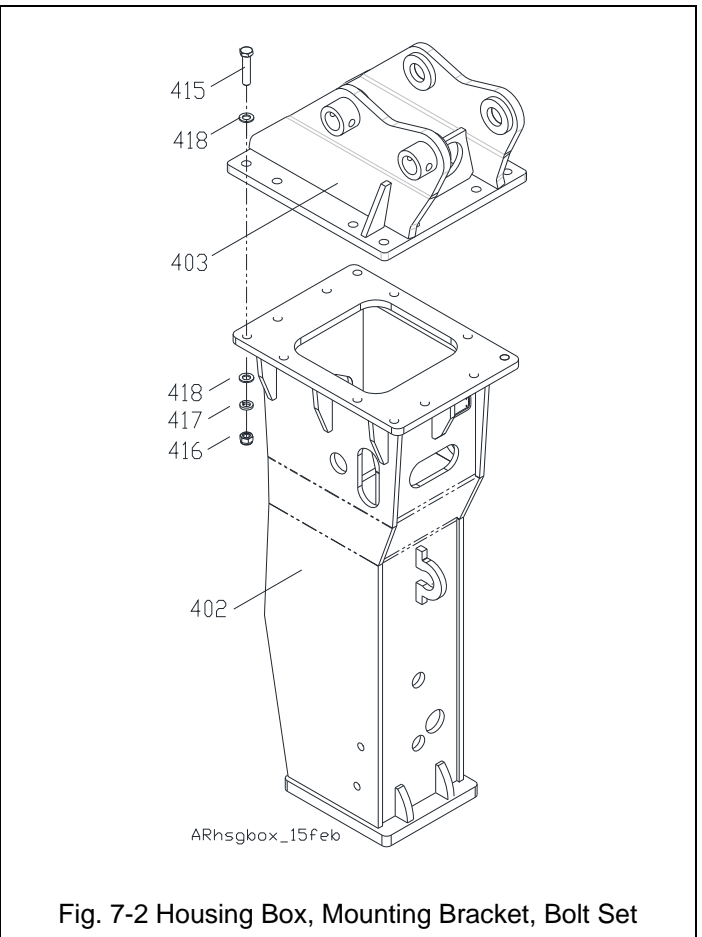



Fig. 7-2 Housing Box, Mounting Bracket, Bolt Set

Table 7.1 Mounting Family & Hardware (Qty)

Family	Breaker Model	415 Bolt	418 FL Washer	417 LK Washer	416 Nut
SR	AR95, AR95B	572352 (10) 18M CL10.9	679422 (20) 18M	571027 (10) 18M	572353 (10) 18M

  Refer to the Safety, Operation and Maintenance manual for the proper tightening torque.

8.0 How To Order Spare Parts

Your local Allied dealer requires complete information to better assist you with questions regarding parts, warranty, operation, maintenance, or repair. This information, Product Name, Model and Serial Number, should be noted in Section 2.3 of this manual.

Product Series / Model Hydraulic Impact Breaker
AR
 Serial No. _____

Please fill out completely

Line	Description	Part Number	Quantity	Price
1				
2				
3				
4				
5				
6				
7				
8				
9				
10				

Contact information

Your Name _____	Company Name _____
Phone _____	Account Number _____
Fax _____	Purchase order _____
Email _____	Shipping method _____

*See note below

Billing Address _____	Shipping Address _____
_____	_____
_____	_____
_____	_____

***Note: All backordered parts will be shipped when available via the same method as the original order unless initialed and checked below:**

Initials _____

Ship complete order only

Ship available parts and contact customer on disposition of backordered parts

Other – specify below

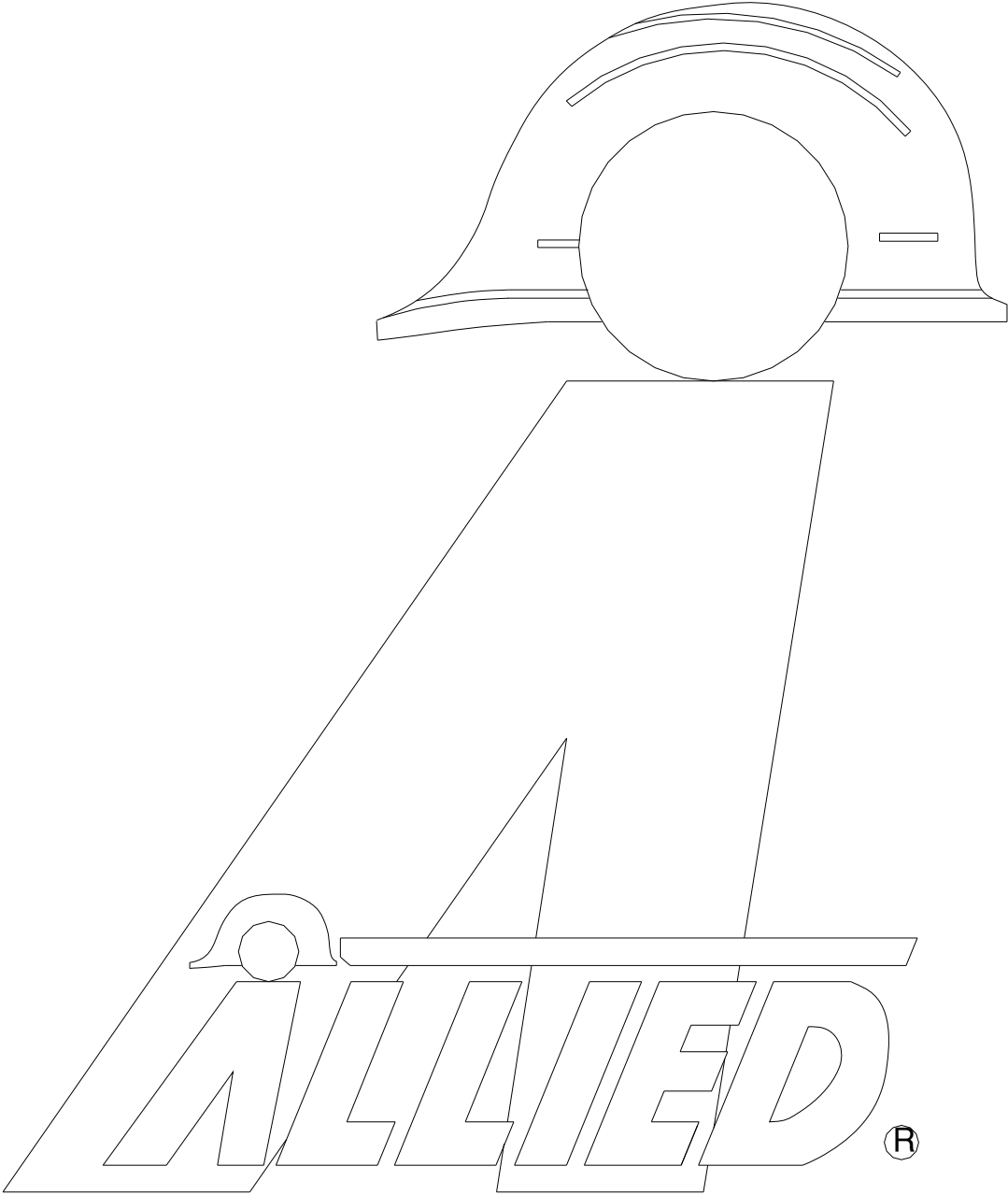

3900 Kelley Avenue, Cleveland, Ohio 44114
Tel: 216-431-2600 Fax: 216-431-2601
e-mail: Sales@AlliedCP.com
website: <http://www.AlliedCP.com>