

PARTS MANUAL

PMRC26EN.A99

CUTTER-CRUSHER

RAMMER RC 26

SERIAL NO.

RC26BD0015-UP

RC26RD0014-UP

TABLE OF CONTENTS

1. Cylinder RC 26	4
2. Hydraulics RC 26	6
3. Brake RC 26	8
4. Hydraulic motor RC 26	9
5. Slew lock RC 26	10
6. Slewing ring RC 26	11
7. Body parts RC 26	12
8. Wear items RC 26	14

GENUINE RAMMER SPARE PARTS

Rammer genuine spare parts are designed and manufactured by using the latest technological knowledge and engineering skills. Rammer spare parts are made of the best available materials with the most advanced manufacturing techniques.

It is important that you use only genuine Rammer spare parts, to ensure easy operation, maintenance and repair of the hammer. Please note that eventual warranty claims will be handled only if you have used genuine Rammer parts in your hammer.

LOCATION OF THE SERIAL NUMBER

It's important to make correct reference to the serial number of the hammer when ordering spare parts. Identification of serial number is the only proper means of maintaining and identifying parts for a specific hammer. The equipment serial number is stamped on the valve body. It is also marked on the CE-marking affixed to hammer's housing.

SPARE PART ORDERS

Quick spare part deliveries are secured by exact orders.

Required information:

- Name of customer and contact person
 - Order number (when available)
 - Delivery address
 - Mode of delivery (air mail etc.)
 - Required delivery date
 - Invoicing address
 - Model and serial number of the hammer
 - Name, number and required amount of spare parts
-

PARTS

1. CYLINDER RC 26

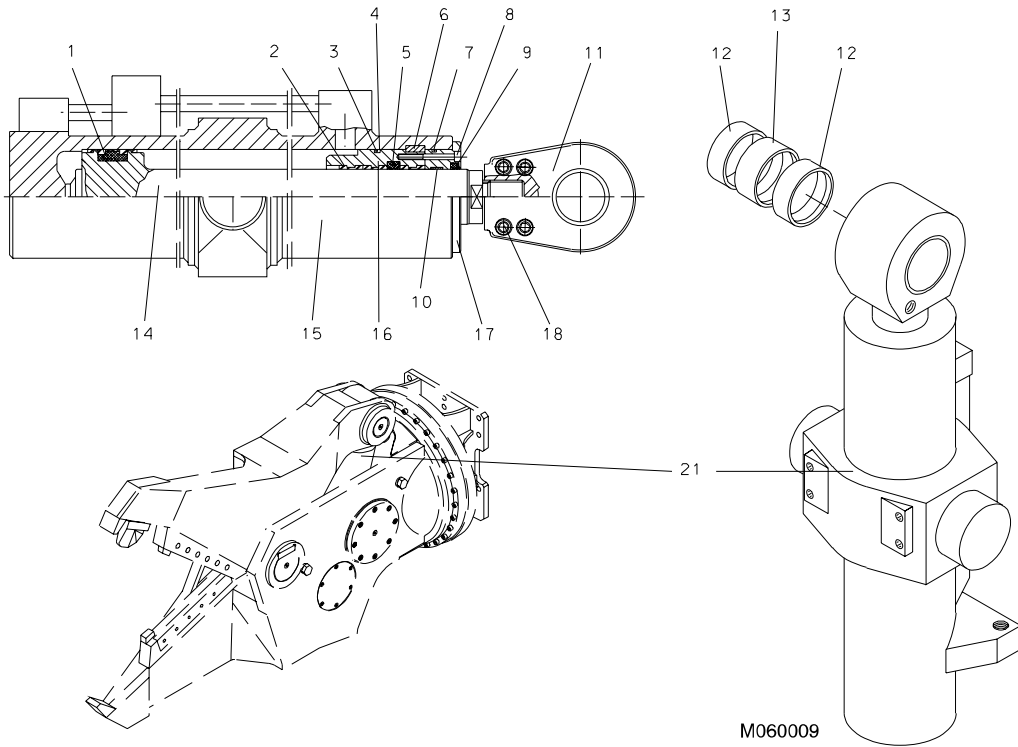

M060009

Item	Description	Part no.	Specification	Note	Qty
21	Hydraulic cylinder, incl. parts 1-18	902695			1
1	Seal	902696			1
2	Steering ring	902602	D110		3
3	O-ring	902697	D190		1
4	Supporting ring	902698	D200		1
5	Seal	902605			1
6	Lock ring	902699			1
7	O-ring	902700	D200		1
8	Hex. socket screw	91107	M12x90-8.8 DIN 912		4
9	Wiper	902609			1
10	Slide ring	902523			1
11	Swivel bushing	902610			1
12	Sliding bearing	902611	WB800 100/105-50		2
13	Sliding bearing	902612	WB800 100/105-30		1
14	Piston rod	902701			1
15	Cylinder body	902702			1
16	Guide	902703			1

Item	Description	Part no.	Specification	Note	Qty
17	Ring	902704			1
18	Hex. socket screw	902706	M16x110-8.8 DIN 912		4
19	Seal set for cylinder	902705			1

2. HYDRAULICS RC 26

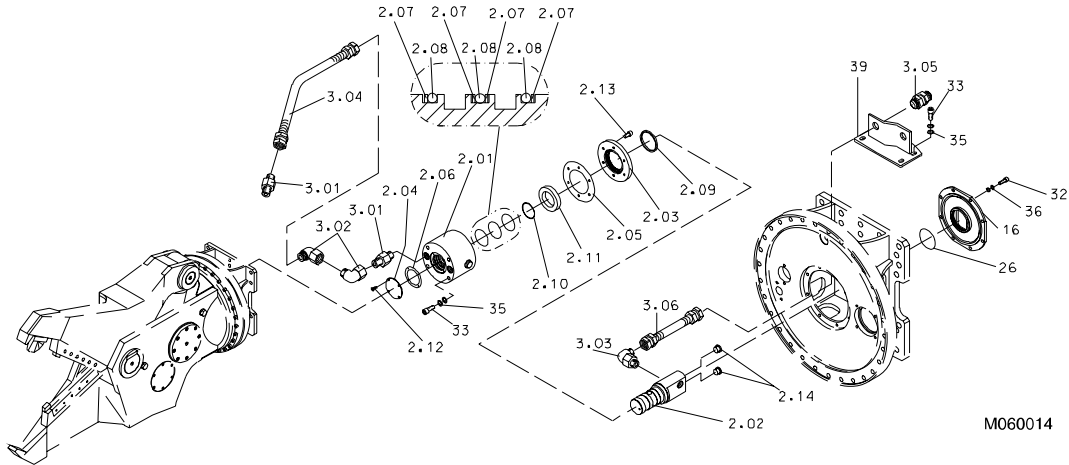

Item	Description	Part no.	Specification	Note	Qty
2.01	Body	140301			1
2.02	Spool	140300			1
2.03	Cover	140048			1
2.04	Cover	140047			1
2.05	Seal	140049			1
2.06	Seal	140050			1
2.07	Supporting ring	901303			4
2.08	O-ring	901302	D72		3
2.09	Wiper	911017	D90		1
2.10	Lock ring	901307			1
2.11	Ball bearing	901305			1
2.12	Hex. socket screw	901306			4
2.13	Hex. socket screw	90501	M10x20-8.8 DIN 912		6
2.14	Flange plug	90401	R3/4		2
3.01	Adapter	901583	F40XS25-1		4
3.02	Elbow	901602	C6XS25		4
3.03	Elbow	901585	C40XS25-1		2
3.04	Hoseassembly	901603			2
3.05	Bulkhead union	90470			2
3.06	Hose assembly	902124			2
16	Slew stopper	140114			1
26	O-ring	901316			1

Item	Description	Part no.	Specification	Note	Qty
32	Hex. socket screw	900046	M12x35-8.8 DIN 912		8
33	Hex. socket screw	91100	M16x40-8.8 DIN 912		8
35	Lock washer	90597	M16 NORD-LOCK		8
36	Lock washer	91012	M12 NORD-LOCK		8
39	Hose clamp	140504			1

3. BRAKE RC 26

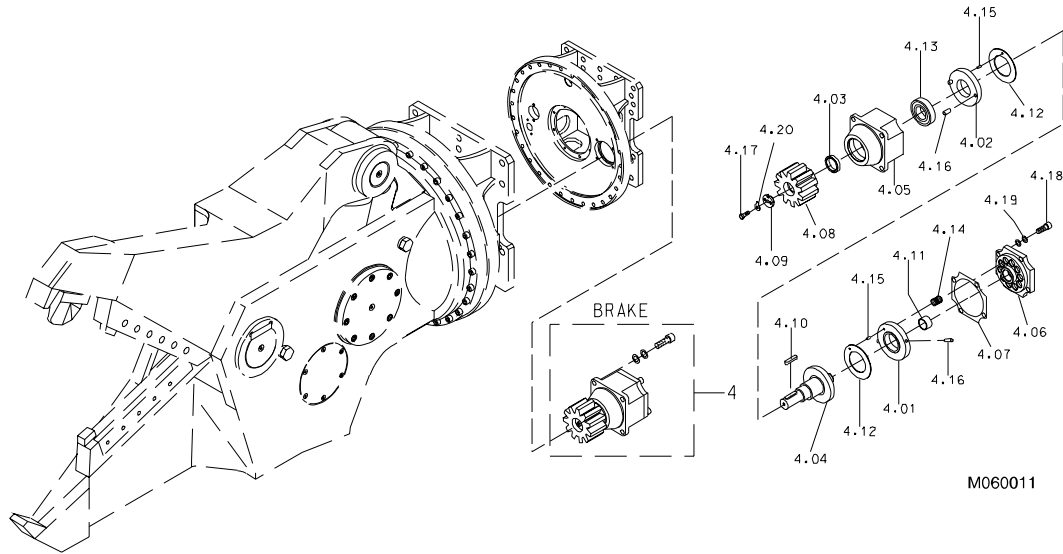

Item	Description	Part no.	Specification	Note	Qty
4	Brake, incl. parts 4.01-4.20	140292			1
4.01	Supporting ring	140195			1
4.02	Supporting ring	140196			1
4.03	Bushing	140197			1
4.04	Shaft	140198			1
4.05	Body	140294			1
4.06	Cover	140293			1
4.07	Spacer plate	140193			2
4.08	Cylindrical gear	140014			1
4.09	Washer	140052			1
4.10	Key	901482			1
4.11	Bush	901483			1
4.12	Plate	901484			2
4.13	Ball bearing	901485			1
4.14	Spring	901486			10
4.15	Parallel pin	901487			2
4.16	Parallel pin	901488			4
4.17	Hex. screw	90570	M8x25-8.8 DIN 933		1
4.18	Hex. socket screw	900046	M12x35-8.8 DIN 912		8
4.19	Lock washer	91012	M12 NORD-LOCK		8
4.20	Washer	902925	DIN 93-8.4-St		1

4. HYDRAULIC MOTOR RC 26

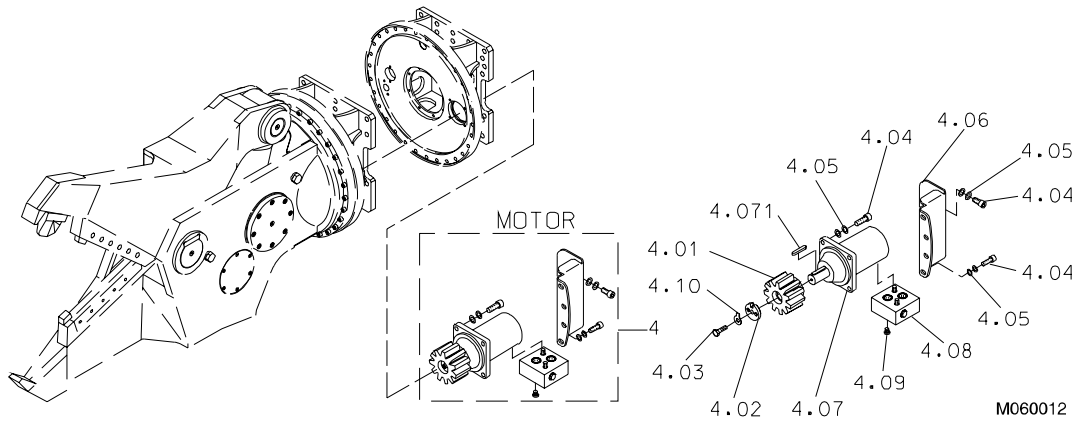

Item	Description	Part no.	Specification	Note	Qty
4	Hydraulic motor, incl. parts 4.01-4.10	140254			1
4.01	Cylindrical gear	140014			1
4.02	Washer	140052			1
4.03	Hex. screw	90570	M8x25-8.8 DIN 933		1
4.04	Hex. socket screw	900046	M12x35-8.8 DIN 912		10
4.05	Lock washer	91012	M12 NORD-LOCK		10
4.06	Casing	140495			1
4.07	Hydraulic motor, incl. part 4.071	901319			1
4.071	Key	901482			1
4.08	Valve	901320			1
4.09	Plug	93066			1
4.10	Washer	902925	DIN 93-8.4-St		1

5. SLEW LOCK RC 26

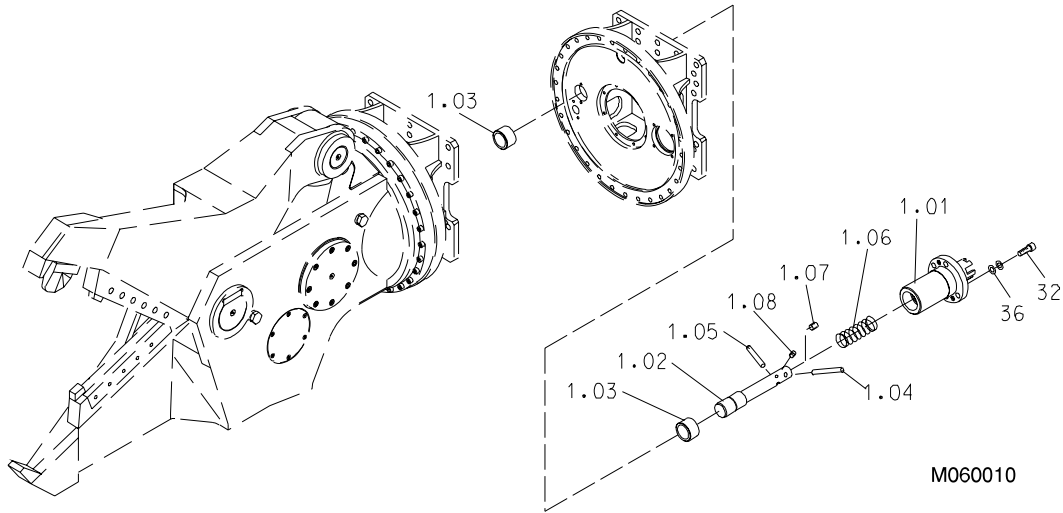

Item	Description	Part no.	Specification	Note	Qty
1.01	Lock bushing	140344			1
1.02	Lock pin	140134			1
1.03	Steering bush	140131			2
1.04	Pin	140127			1
1.05	Pin	140126			1
1.06	Spring	140125			1
1.07	Retaining screw	901314			1
1.08	Retaining screw	901313			1
32	Hex. socket screw	900046	M12x35-8.8 DIN 912		4
36	Lock washer	91012	M12 NORD-LOCK		4

6. SLEWING RING RC 26

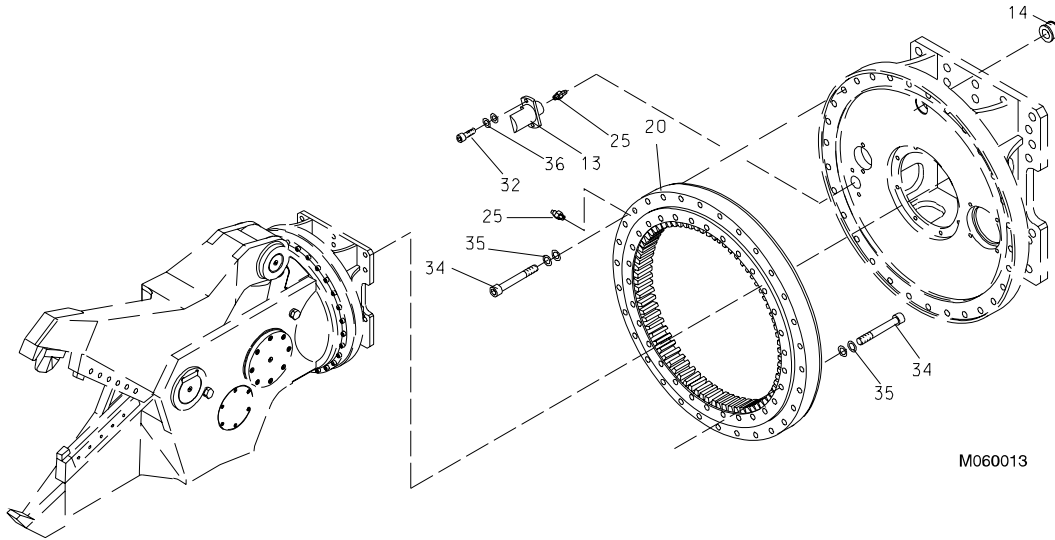

Item	Description	Part no.	Specification	Note	Qty
13	Guide	140051			1
14	Rubber plug	400491			1
20	Slewing ring	901318			1
20.1	Seal set for slewing ring	902646			1
25	Grease nipple	90204	A M10x1		2
32	Hex. socket screw	900046	M12x35-8.8 DIN 912		2
34	Hex. socket screw	902915			60
35	Lock washer	90597	M16 NORD-LOCK		60
36	Lock washer	91012	M12 NORD-LOCK		2

7. BODY PARTS RC 26

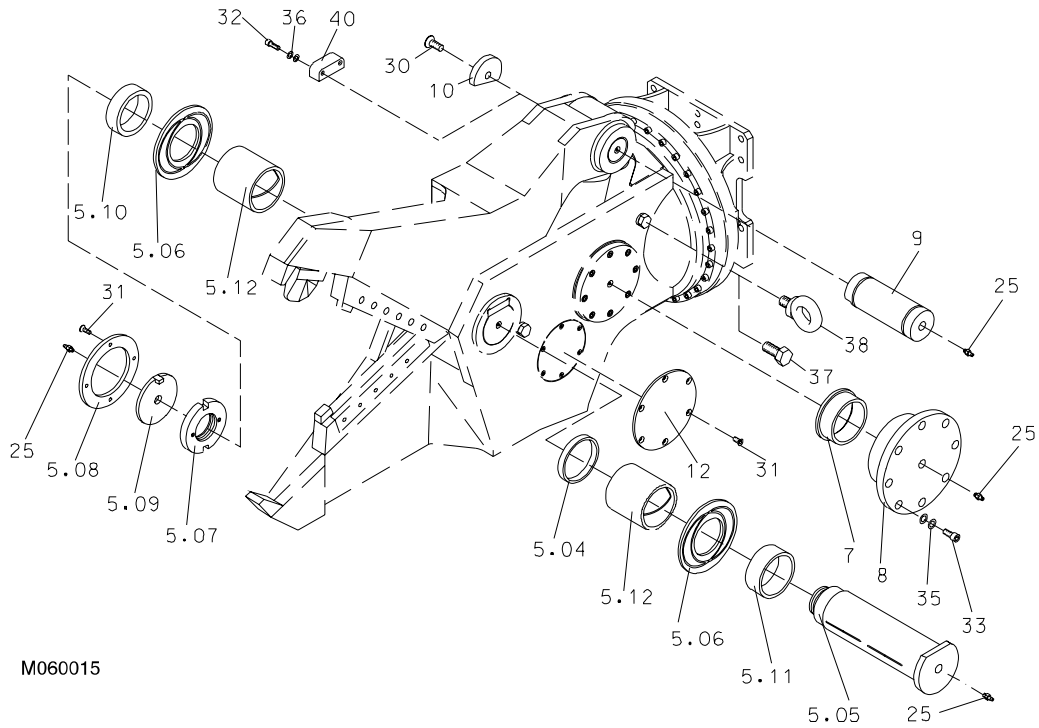

M060015

Item	Description	Part no.	Specification	Note	Qty
5.04	Bushing	140345			1
5.05	Shaft	140119			1
5.06	Spacer plate	140118			2
5.07	Axle nut	140117			1
5.08	Cover holder	140044			1
5.09	Cover	140042			1
5.10	Bush	140115			1
5.11	Bush	140116			1
5.12	Bush	140121			2
7	Bush	140038			2
8	Cap	140035			2
9	Shaft	140039			1
10	Cover	140040			1
12	Cover	140027			2
25	Grease nipple	90204	A M10x1		5
30	Hex. socket screw	901287	M20x40-8.8 DIN 7991		1
31	Hex. socket screw	901286	M10x25-8.8 DIN 7991		12

Item	Description	Part no.	Specification	Note	Qty
32	Hex. socket screw	900046	M12x35-8.8 DIN 912		16
33	Hex. socket screw	91100	M16x40-8.8 DIN 912		16
35	Lock washer	90597	M16 NORD-LOCK		16
36	Lock washer	91012	M12 NORD-LOCK		16
37	Hex. screw	900026	M30x40-8.8 DIN 933		2
38	Lifting eye	90705	M30 DIN 580		2
40	Plate	140526			1
43	Label set	141051			1

8. WEAR ITEMS RC 26

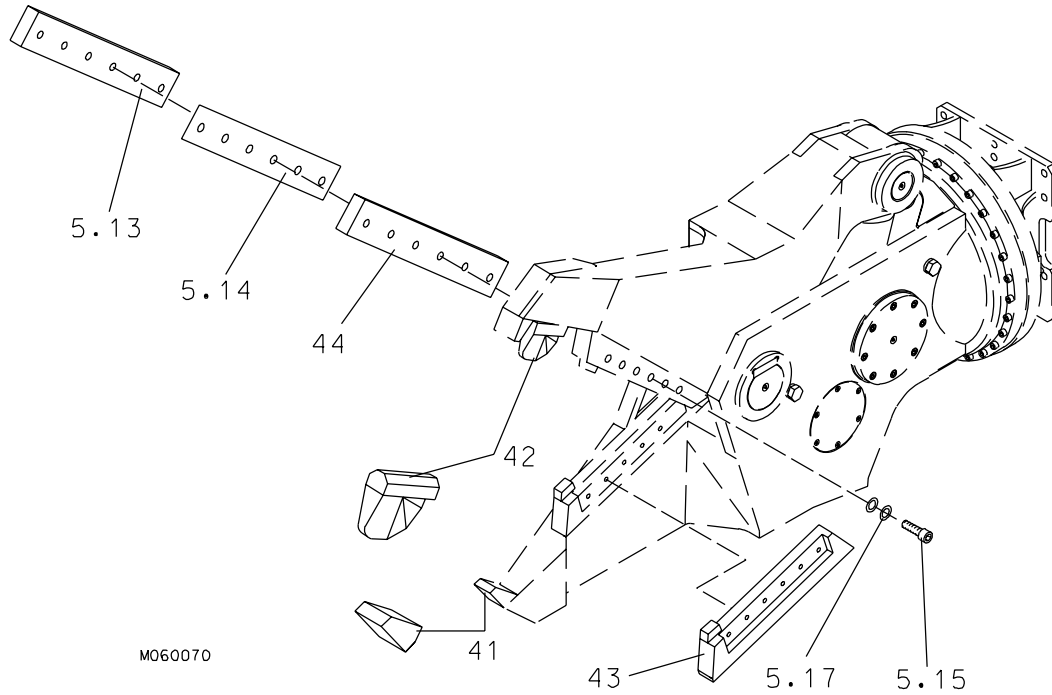

Item	Description	Part no.	Specification	Note	Qty
5.13	Cutting blade	140085			2
5.14	Shim plate	140108			x
5.15	Hex. socket screw	901309	M16x55-8.8 DIN 912		12
5.17	Lock washer	90597	M16 NORD-LOCK		12
41	Front tooth	140004			2
42	Breaking tooth	140025			1
43	Cutting blade seat	140009			1
44	Cutting blade seat	140848			1

SANDVIK TAMROCK CORP.
Breakers Lahti
Taivalkatu 8, P.O. Box 165, FIN-15101 Lahti, Finland
Phone Int. +358 205 44 161, Telefax Int. +358 205 44 160,
Internet <http://www.rammer.com>