

Variable Mounting System™

Allied's Variable Mounting System (VMS) for Hy-Ram® and Ho-Pac® attachments



With VMS, it's now as simple as plugs, collars and pins to match our attachments to your machine.

Today's equipment users demand that carriers perform multiple functions during a project and have the ability to quickly switch attachments. Attachments may be used with more than one carrier as job requirements and availability change.

Allied has developed a patented system – the Variable Mounting System™ – to easily mount Allied Hy-Ram® and Ho-Pac® attachments to loader/backhoes and excavators.

The Variable Mounting System (VMS) is a unique system that allows attachments to be “custom-fit” to match the stick/link width, pin diameters and pin centers of most carriers and to fit the requirements of many pin grabbing quick-couplers.

A complete VMS mounting kit (including plugs, collars, pins and fasteners) can be installed on any VMS designed top-mounting bracket or mounting frame. By replacing only the necessary components, the attachment may quickly be moved from one carrier to another in the same class or adapted to a different quick-coupler system.

VMS advantages include:

- Creates a “custom” or “purpose-built” mounting combination matching carrier dimensions
- Fits many pin grabbing quick-coupler systems
- Attachments can easily be moved from one carrier to another
- One top-mounting bracket or frame can be adapted to various carriers in the same weight class (eliminates the need for additional mounting or adapter brackets)
- Improved attachment versatility and utilization
- Mounting kit component installation requires no special tools

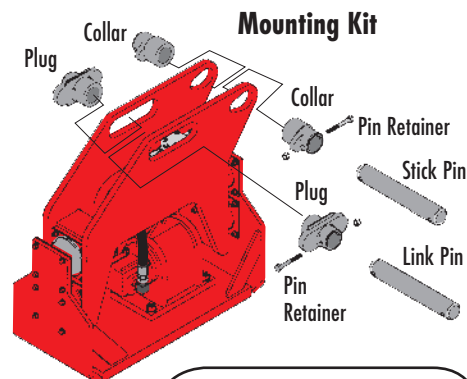

A mounting kit consists of a combination of 2 Collars, 2 Plugs, 2 Pins and 4 Fasteners to match carrier dimensions. Individual replacement components to match alternative carriers are available.

A wide variety of VMS mounting brackets, kits and components are available from Allied. Contact your Allied Distributor to learn more about how this patented, versatile system can help you to quickly and efficiently get the job done.

VMS Top-Mounting CS Bracket, Hammer Side-Plate and Ho-Pac® Frame Specifications

VMS Sizes		V10	V13	V16	V17	V21
Inside Bracket/Frame Spacing	in.	10.63	13.50	16.75	17.75	21.25
Top-Mounting Bracket Type		BCS/SCS	SCS/MCS	MCS/LCS	MCS/LCS	LCS
Hammer Side Plate (for applicable models)		Yes	Yes	No	No	No
Ho-Pac Frame (for applicable models)		Yes	Yes	Yes	Yes	Yes
Carrier Dimension Ranges						
Stick/Link Pin Diameter	in.	1.50 to 2.60	2.16 to 3.54	2.16 to 3.54	2.95 to 4.33	2.95 to 4.33
	(mm)	(38 to 65)	(55 to 90)	(55 to 90)	(75 to 110)	(75 to 110)
Stick/Link Width	in.	5.00 to 10.13	8.50 to 13.00	12.00 to 16.25	12.00 to 17.25	15.50 to 20.75
Pin Center to Center	in.	10.00 to 15.00	14.25 to 20.25	14.25 to 20.25	15.50 to 22.50	17.00 to 24.00

V10/ V13/V16/V17/V21 indicate nominal bracket or frame inside spacing in inches.

Mounting Bracket Type Descriptions: BCS-Backhoe Top-Mounting SCS-Small Excavator/Backhoe Top-Mounting MCS-Medium Excavator Top-Mounting LCS-Large Excavator Top-Mounting



VMS Top-Mounting CS Bracket



VMS Ho-Pac® Side-Frame

For sales and service, contact your Allied Distributor:



3900 Kelley Avenue, Cleveland, Ohio 44114
Tel: 216-431-2600 Fax: 216-431-2601
e-mail: Sales@AlliedCP.com
website: <http://www.AlliedCP.com>